

FICHE D'HOMOLOGATION HOMOLOGATION FORM



COMMISSION INTERNATIONALE DE KARTING - FIA



MOTEUR / ENGINE OK

Constructeur	<i>Manufacturer</i>	Dipl. Ing. Karlheinz Hahn
Marque	<i>Make</i>	REXON MOTORS
Modèle	<i>Model</i>	PRIMABALLERINA OK
Type d'admission	<i>Inlet type</i>	REED VALVE
Durée de l'homologation	<i>Validity of the homologation</i>	3 ans / 3 years
Nombre de pages	<i>Number of pages</i>	18

La présente Fiche d'Homologation reproduit descriptions, illustrations et dimensions du moteur au moment de l'homologation par la CIK-FIA.

This Homologation Form reproduces descriptions, illustrations and dimensions of the engine at the time the CIK-FIA conducted the homologation.



PHOTO DU MOTEUR CÔTÉ PIGNON /
PHOTO OF DRIVE SIDE OF ENGINE

PHOTO DU MOTEUR CÔTÉ OPPOSÉ /
PHOTO OF OPPOSITE SIDE OF ENGINE

Signature et tampon de l'ASN
Signature and stamp of the ASN

Signature et tampon de la CIK-FIA /
Signature and stamp of the CIK-FIA

C. S. U.

INFORMATIONS TECHNIQUES

TECHNICAL INFORMATION

A	CARACTÉRISTIQUES	A	CHARACTERISTICS
	Le nombre de décimales doit être de 2 ou en accord avec la tolérance appliquée.		The number of decimal places must be 2 or comply with the relevant tolerance.
			Tolérances et remarques / Tolerances and remarks
	Cylindre		Cylinder
	Volume du cylindre		Volume of cylinder 124.96 cm³
	Alésage d'origine		Original bore 53.97 mm
	Alésage théorique maximum		Theoretical maximum bore 54.08 mm
	Course		Stroke 54.4 mm
	Nombre de canaux de transfert, cylindre/carter		Number of transfer ducts, cylinder/sump 5 / 3
	Nombre de lumières / canaux d'échappement		Number of exhaust ports / ducts 3
	Forme de la chambre de combustion		Shape of the combustion chamber SPHERICAL
	Vilebrequin		Crankshaft
	Nombre de paliers		Number of bearings 2
	Diamètre des paliers		Diameter of bearings 25 mm
	Poids du vilebrequin		Weight of crankshaft 1900 g
	Arbre d'équilibrage		Balance shaft
	Poids de l'arbre d'équilibrage		Weight of balance shaft 266 g
	Pourcentage d'Equilibrage		Percentage of balancing 25 %
	Bielle		Connecting rod
	Longueur (entre-axe) de la bielle		Length between the axes of the connecting rod 104 mm
	Diamètre de la tête de bielle		Diameter of big end 26 mm
	Diamètre du pied de bielle		Diameter of small end 19 mm
	Poids de la bielle		Weight of the connecting rod 96 g



Piston	Piston		
Nombre de ségments du piston	<i>Number of piston rings</i>	1	
Poids du piston nu ségments du piston inclus	<i>Weight of the bare piston including piston rings</i>	94 g	minimum
Axe du piston	Gudgeon pin		
Poids	<i>Weight</i>	28 g	minimum

B	ANGLES D'OUVERTURE	B	OPENING ANGLES
de l'échappement	of the exhaust	selon les reglements	according to the regulations

C	MATÉRIAU	C	MATERIAL
Culasse	<i>Cylinder head</i>		ALUMINIUM/COPPER ALLOY
Cylindre	<i>Cylinder</i>		ALUMINIUM ALLOY
Carter	<i>Sump</i>		ALUMINIUM ALLOY
Vilebrequin	<i>Crankshaft</i>		STEEL
Bielle	<i>Connecting rod</i>		STEEL
Piston	<i>Piston</i>		ALUMINIUM ALLOY

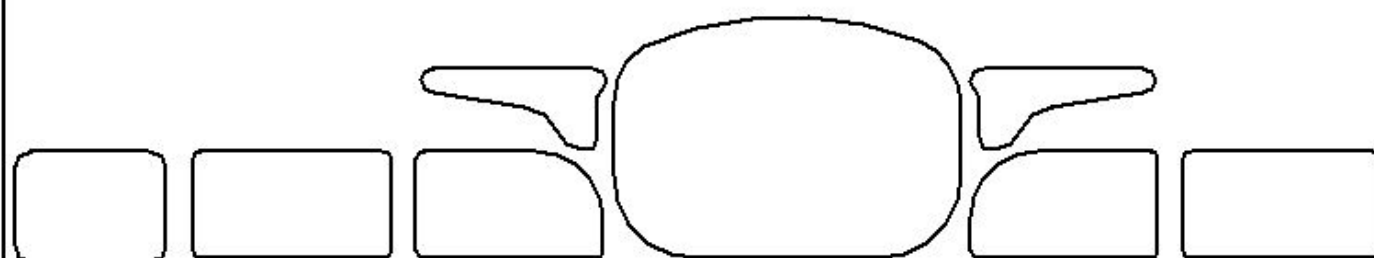


D	PHOTOS, DESSINS & GRAPHIQUES	D	PHOTOS, DRAWINGS & GRAPHS
---	------------------------------	---	---------------------------

D.1 CYLINDRE / CYLINDER UNIT

DESSIN DU DÉVELOPPEMENT DU CYLINDRE
sans dimensions

*DRAWING OF THE CYLINDER DEVELOPMENT
without dimensions*

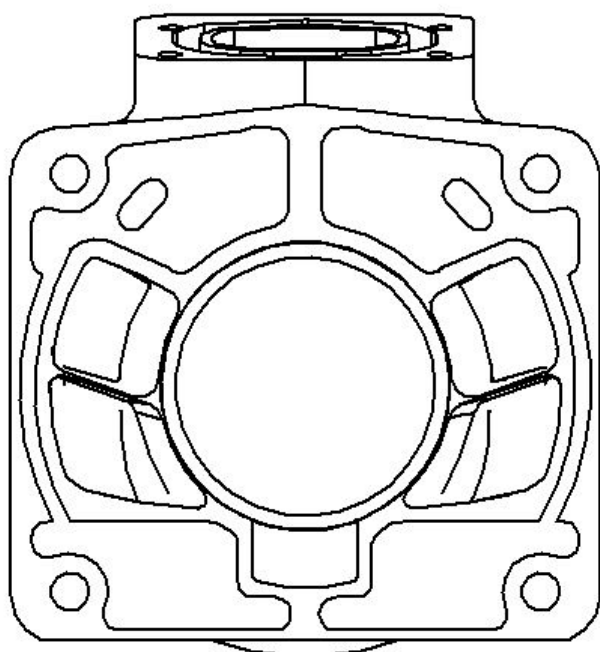


DESSIN DU PIED
DU CYLINDRE
sans dimensions

*DRAWING OF THE
CYLINDER BASE
without dimensions*

PHOTO DU PIED
DU CYLINDRE

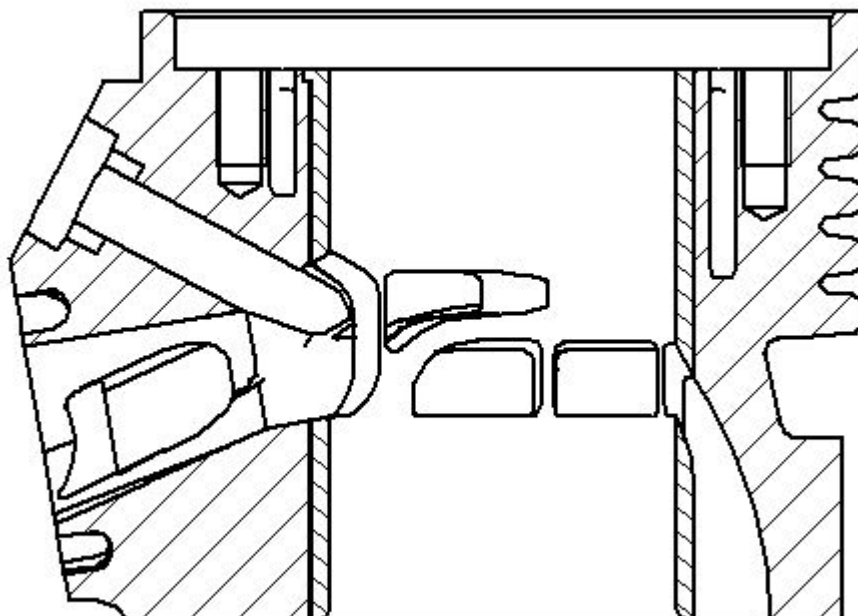
*PHOTO OF THE
CYLINDER BASE*



Section D.1

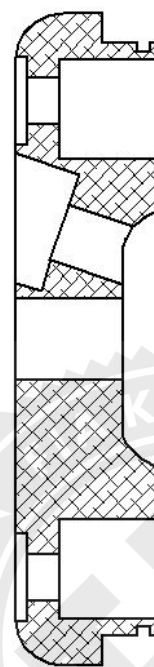
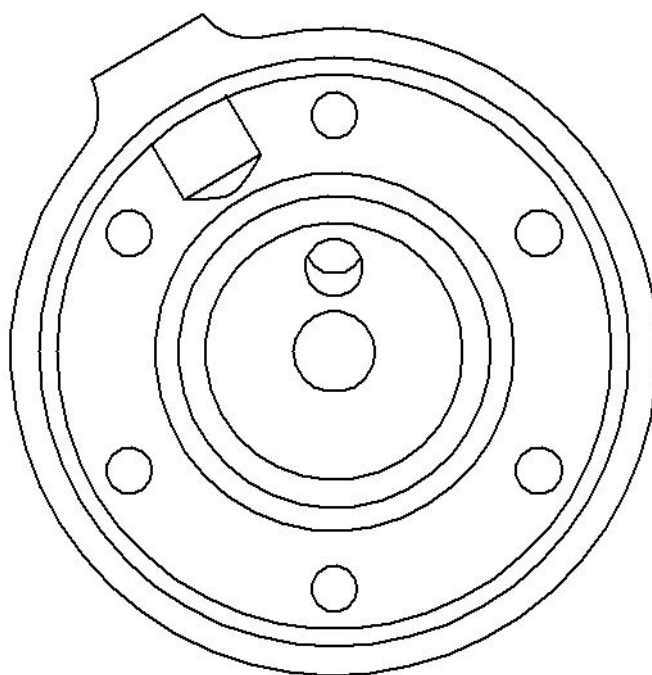
VUE EN COUPE VERTICALE DU CYLINDRE
AVEC LA CHEMISE, sans dimensions

VERTICAL CROSS SECTION VIEW OF
CYLINDER WITH LINER, without dimensions



DESSIN DE LA CULASSE ET DE LA CHAMBRE
DE COMBUSTION, sans dimensions

DRAWING OF THE CYLINDER HEAD AND THE
COMBUSTION CHAMBER, without dimensions



**D.2 VILEBREQUIN, BIELLE, PISTON & CARTERS /
CRANKSHAFT, CONROD, PISTON & CRANKCASE**

PHOTO DE L'EMBIELLAGE /
PHOTO OF THE CRANKSHAFT & CONROD

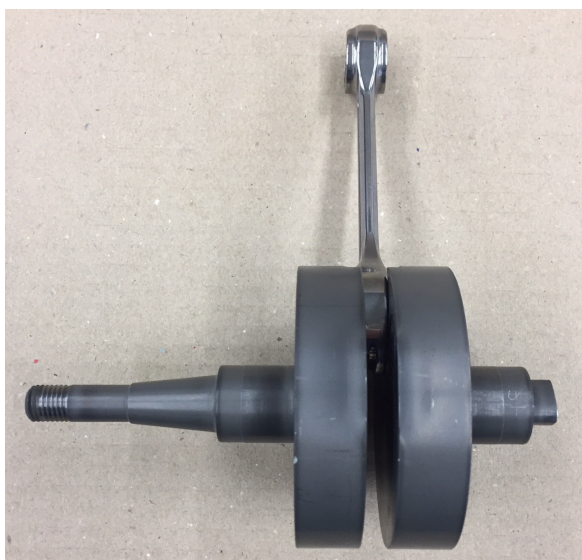
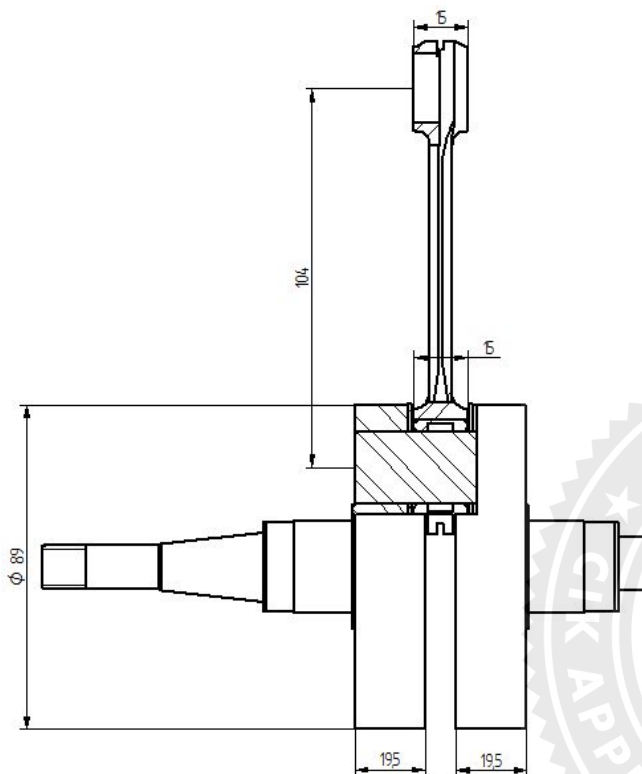


PHOTO DE LA BIELLE /
PHOTO OF THE CONROD

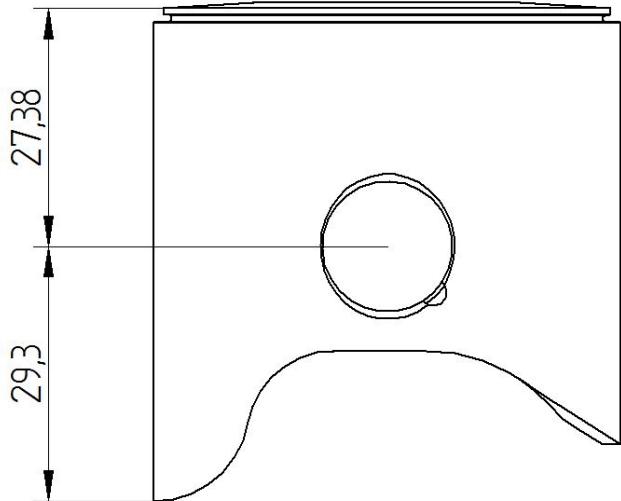
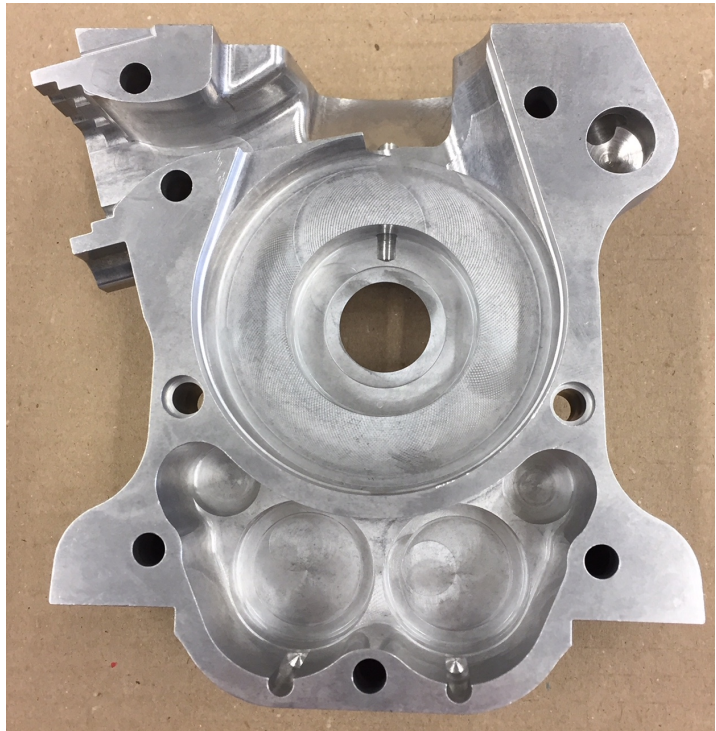





DESSIN DE L'ENSEMBLE VILEBREQUIN -
BIELLE (dimensions sans tolérances: largeurs
ped & tête de bielle, largeur & diamètre des
contrepoids et largeur de vilebrequin)

*DRAWING OF THE CRANKSHAFT - CON ROD
UNIT (dimension without tolerances, big & small
ends thickness, crank mass thickness & diameter
and thickness of crankshaft)*



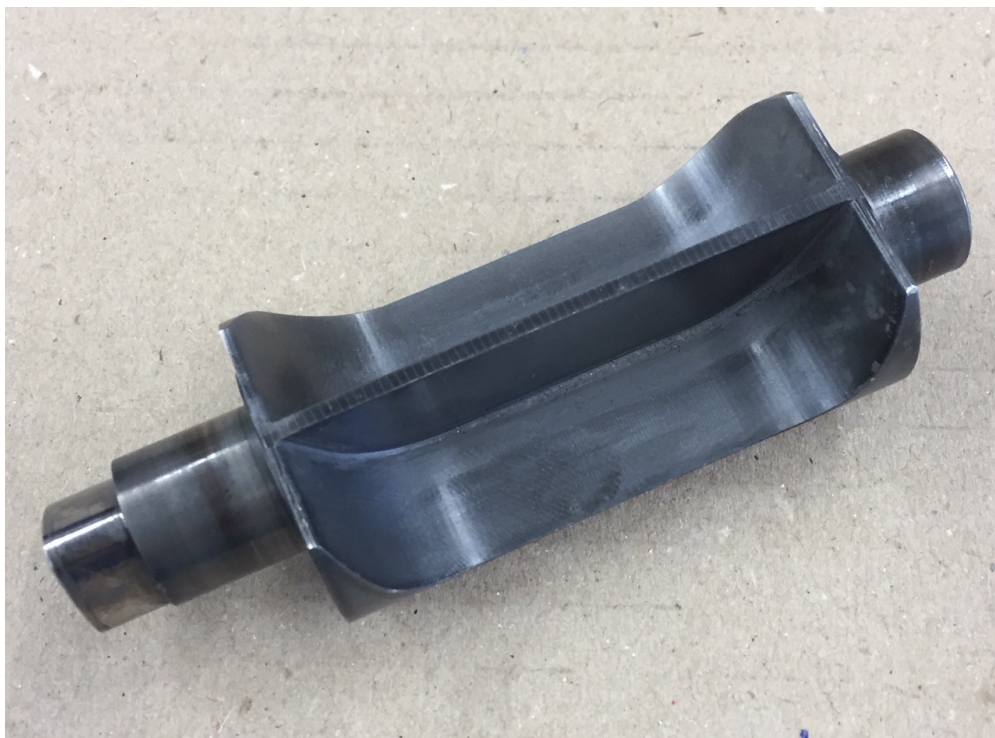
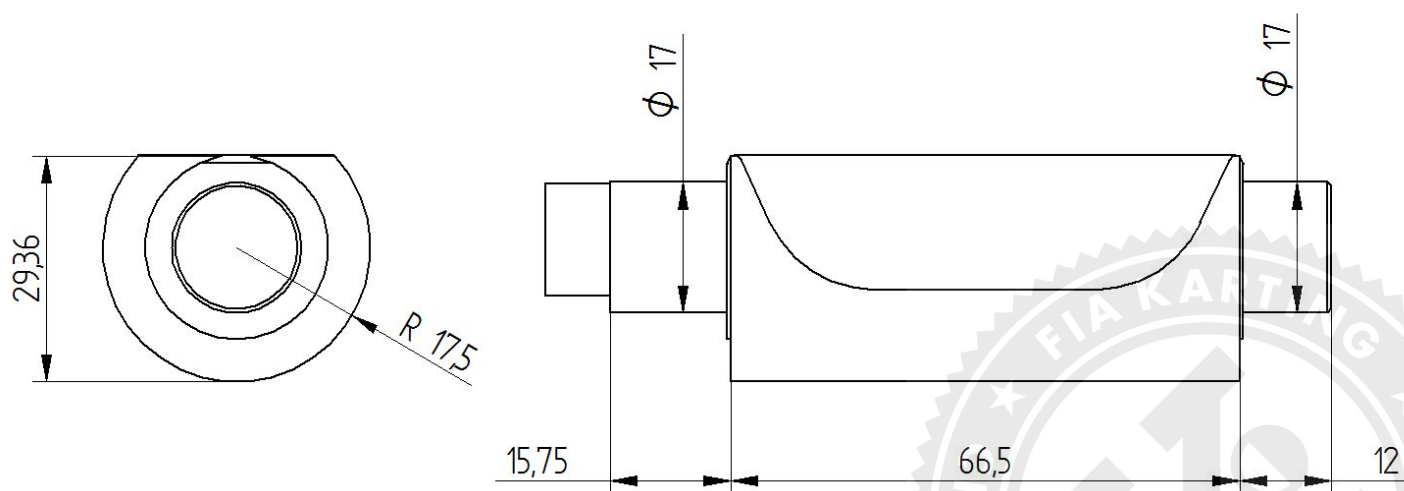
.Section D.2

DESSIN DU PISTON (dimensions principale sans tolérances)		DRAWING OF THE PISTON (main dimensions without tolerances)	
			
PHOTO DE L'INTÉRIEURE DU CARTER DROIT	PHOTO OF THE INSIDE OF THE RH CRANKCASE	PHOTO DE L'INTÉRIEURE DU CARTER GAUCHE	PHOTO OF THE INSIDE OF THE LH CRANKCASE
			

D.3 ARBRE D'ÉQUILIBRAGE / BALANCE SHAFT

PHOTO DE L'ARBRE D'ÉQUILIBRAGE

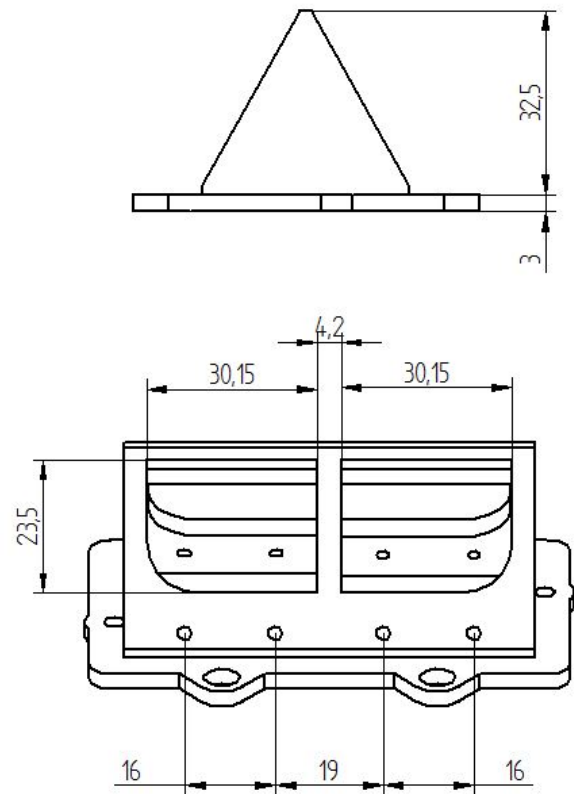
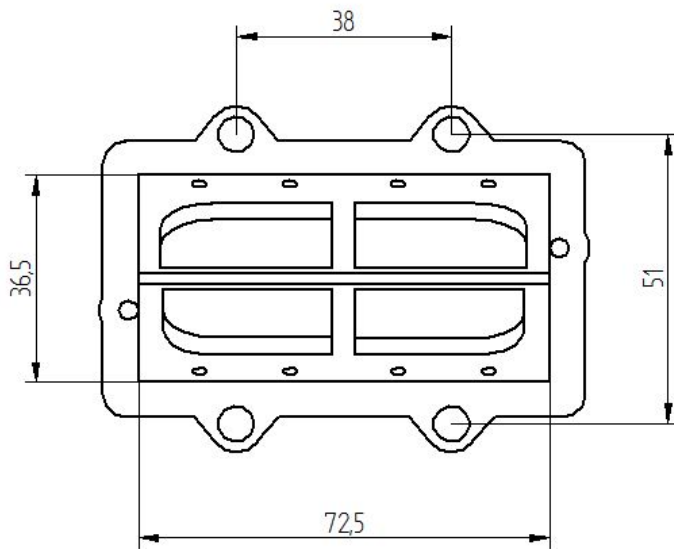
PHOTO OF THE BALANCE SHAFT

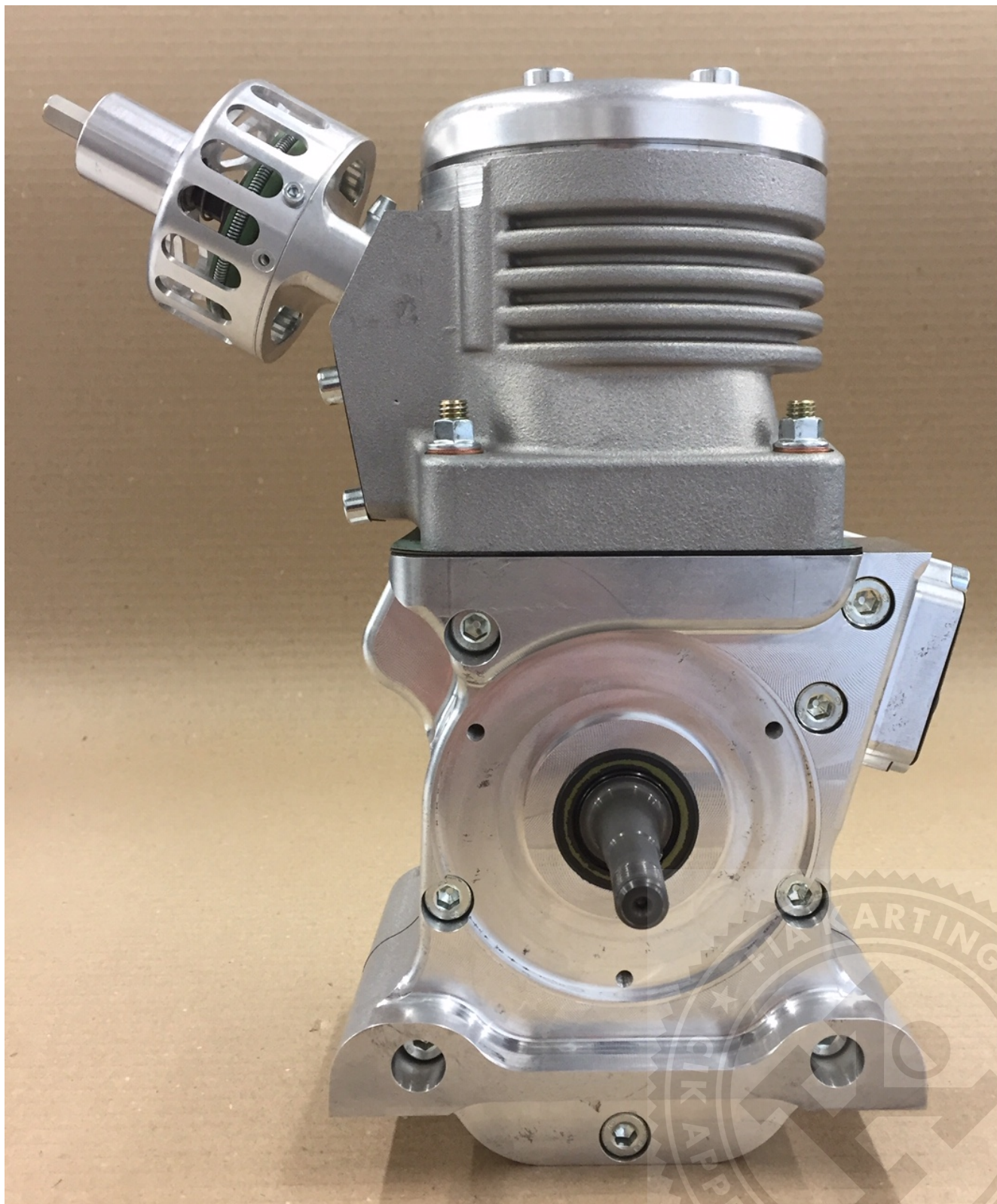
DESSIN DE L'ARBRE D'ÉQUILIBRAGE
(dimensions sans tolérances)DRAWING OF THE BALANCE SHAFT
(dimensions without tolerances)

D.4 CLAPETS / REED VALVE

DESSIN DE LA BOÎTE À CLAPETS
(dimensions sans tolérances)

*DRAWING OF THE REED VALVE
(dimensions without tolerances)*



D.5 MOTEUR / ENGINEPHOTO DU MOTEUR COMPLET
COTÉ PIGNONPHOTO OF THE DRIVE SIDE OF THE
COMPLETE ENGINE

035-ES-17

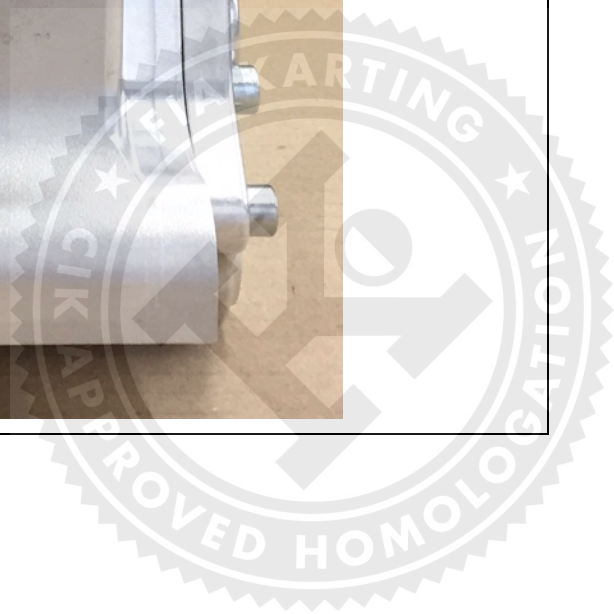
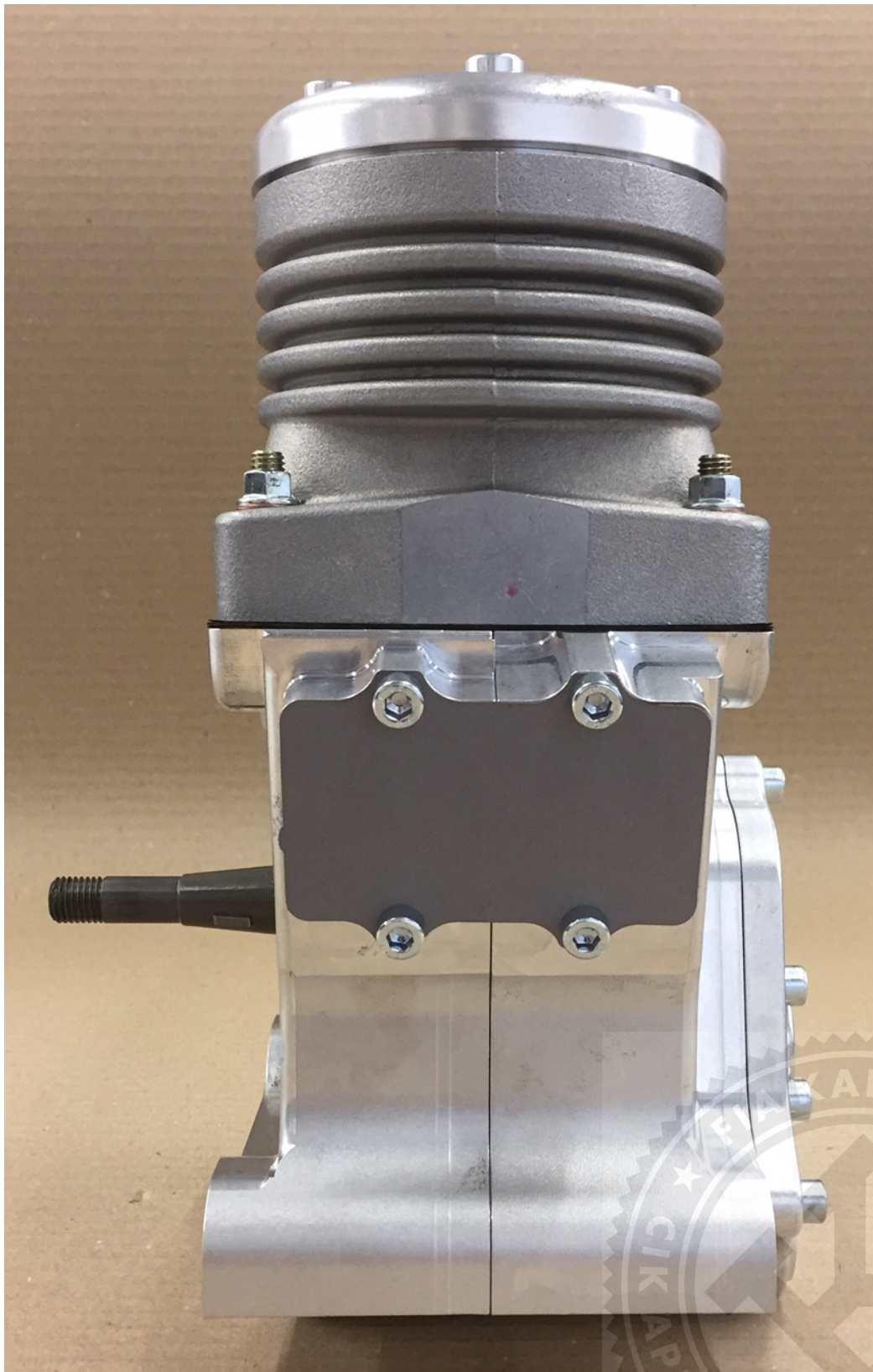
PHOTO DU MOTEUR COMPLET
COTÉ OPPOSÉ AU PIGNON

PHOTO OF THE OPPOSITE DRIVE SIDE
OF THE COMPLETE ENGINE



PHOTO DE L'AVANT
DU MOTEUR COMPLET

*PHOTO OF THE FRONT
OF THE COMPLETE ENGINE*



035-ES-17

PHOTO DE L'ARRIÈRE
DU MOTEUR COMPLET

PHOTO OF THE REAR
OF THE COMPLETE ENGINE



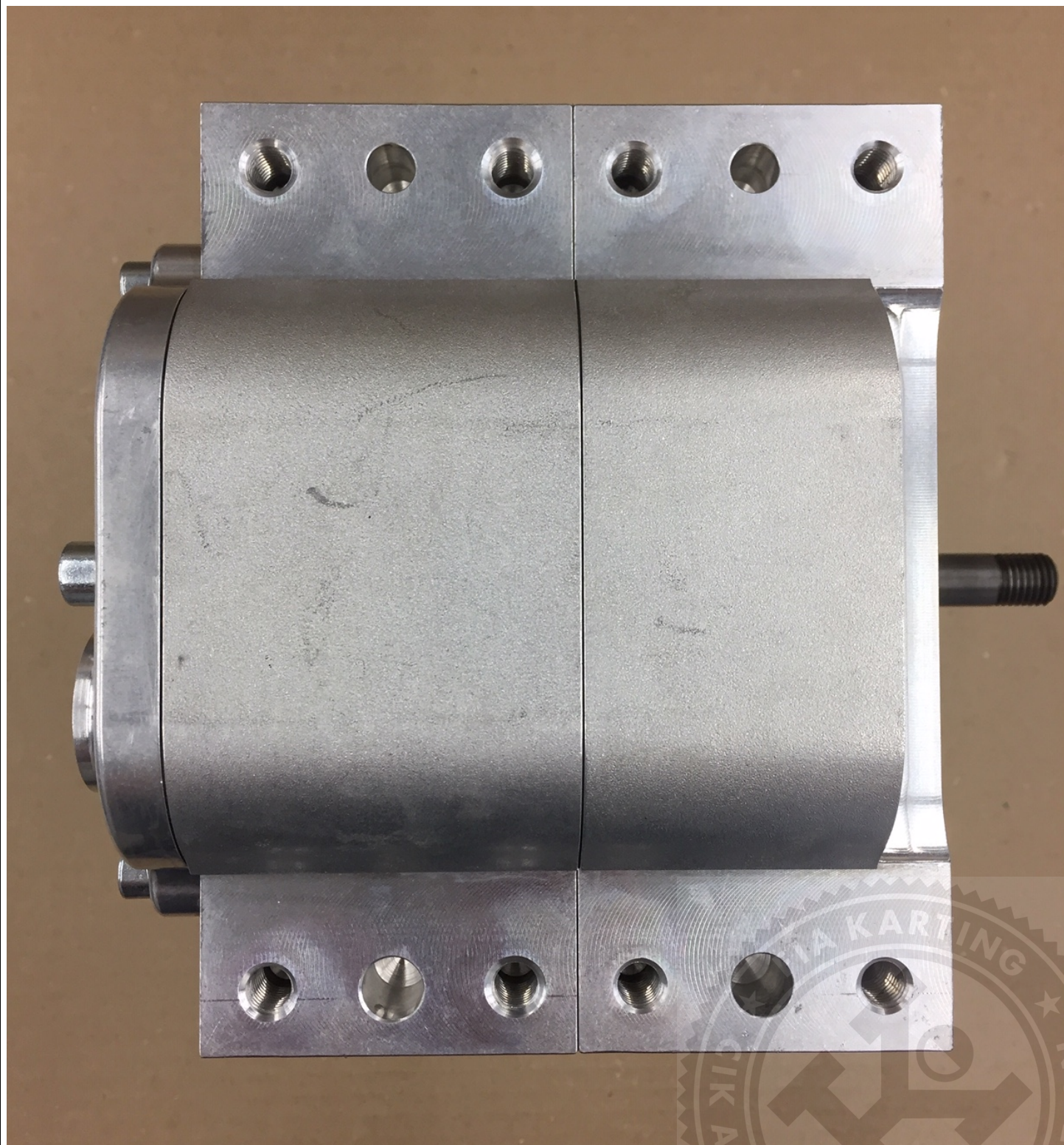
PHOTO DU MOTEUR COMPLET
VU DU HAUT

PHOTO OF THE COMPLETE ENGINE
TAKEN FROM ABOVE

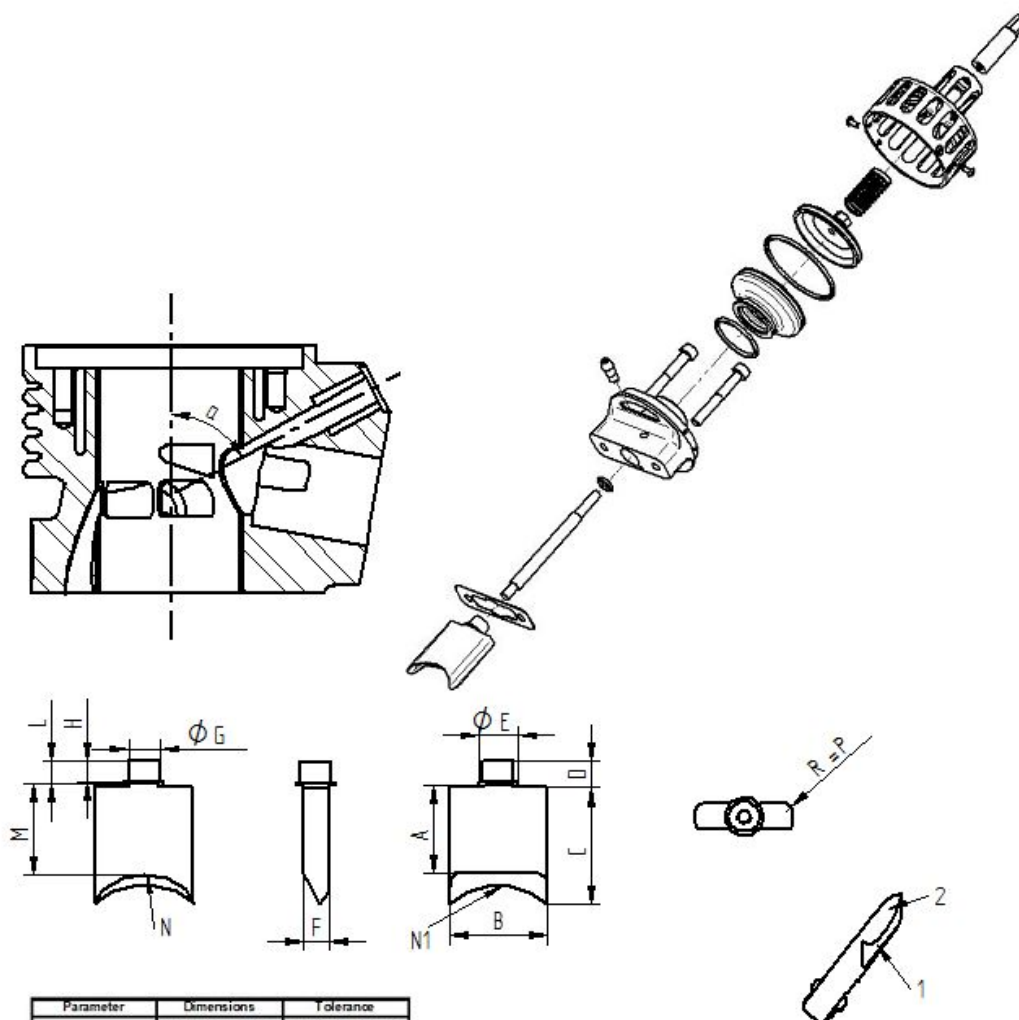


PHOTO DU MOTEUR COMPLET
VU DU DESSOUS

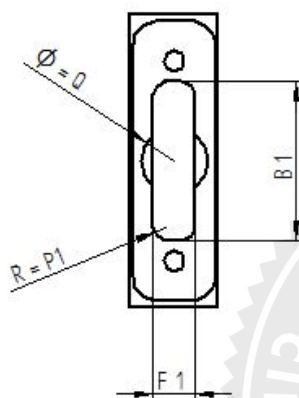
*PHOTO OF THE COMPLETE ENGINE
TAKEN FROM BELOW*



D.6 POWER VALVE

DESSIN EXPLOSE ET DENOMINATION DES
ELEMENTS DE LA POWER VALVEEXPLODED DRAWING AND DESIGNATION OF
THE POWER VALVE COMPONENTS

Parameter	Dimensions	Tolerance
	in mm (or ° if angle)	in mm (or ° if angle)
A	29,5	+/-0.5
B	38	+/-0.1
C	45	+/-0.5
D	10	+/-0.1
E	15	+/-0.1
F	10	+/-0.1
G	12	+/-0.1
H	8	+/-0.1
L	9	+/-0.1
M	35	+/-0.5
N (3D surface)	26	+/-0.5
N1 (3D surface)	29,5	+/-0.5
P	3	+/-0.1
Q	15,5	+/-0.1
α	62	+/-2
B1	38,2	+/-0.2
F1	10,2	+/-0.2
P1	3,2	+/-0.2
Z	4	Maximum



Le dessin explosé de la power valve devra comprendre le tableau indiquant toutes les dimensions indiquées sur le dessin technique n° 22, y compris celles marquées « free ».











The exploded view of the power valve shall include the table indicating all the measurements shown on the technical drawing No. 22, including those marked "free".















E. MARQUAGE PIECES PRINCIPALES / MAIN PARTS MARKING

**Pour chaque pièce, photo globale avec le marquage et photo avec zoom sur le marquage /
For each part, global picture with marking and zoom picture on marking**

1. Fondries de carterdroit et gauche
2. Fondries de cylindre
3. Culasse
4. Chemise en fonte
5. Demi-vilebrequins
6. Bielle
7. Piston
8. Arbre d'équilibrage
9. Engrenages
10. Couvercle d'engrenages
11. Couvercle (plastique) de la power valve
12. Guillotine de la power valve

1. Castings of LH & RH crankcase
2. Castings of cylinder
3. Cylinder head
4. Cast iron liner
5. Half-crankshafts
6. Conrod
7. Piston
8. Balancer shaft
9. Gears
10. Gears cover
11. Power valve (plastic) cover
12. Power valve slide

Pièces N° / Parts no.	Photo d'ensemble / Overall picture	Zoom
1		
1		
2		
3		
4		

5		
6		
7		
8		
9		
10		
11		
12	